

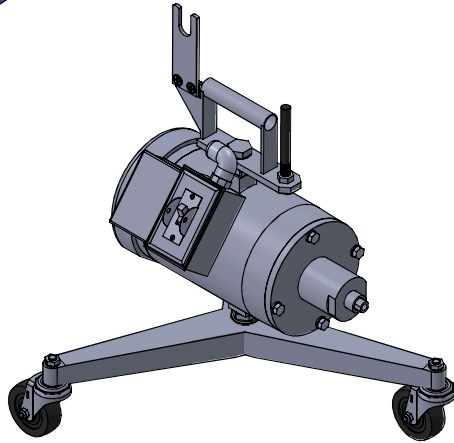

# OPERATING INSTRUCTIONS FOR REMINGTON MODEL 5FG-EA SERIES MOTOR ASSEMBLY



## SPECIFICATIONS

•Motor Speed	3450 RPM
•Bearings	Shielded Ball
•Voltage, 60 Cycle, 3 Phase	220/440
•Switch	Manual Toggle Type Double Pole
•Model No.	5FG-EA
•Horsepower	2 HP
•Ampere Rating	5.8 @ 230V 2.9 @ 460V
•Motor Shaft Thread	.375-24 Int-thd
•Motor Housing Thread	1.25-20 Ext-thd

## STANDARD SHAFTS AND HOUSINGS

Shaft Size and Number	32957A (5/8" x 7')
Housing Size and Number	4790A (5/8" x 7')

## TO GET EFFICIENT AND RELIABLE SERVICE FROM THIS UNIT, OBSERVE THE FOLLOWING INSTRUCTIONS:

### GROUNDING

•All motors have a green grounding lead that should be connected to ground in accordance with the National Electric Code. This is for protection against electric shock. The green grounding conductor is connected to the frame of the motor.

•Wire sizes too small for the cord length cause a drop in voltage at the motor terminals and failure to observe this extension cord data will result in overheating, loss of speed and power, and in a short time, damage the motor.

**CAUTION:** If line voltage is low, use at least the next larger wire size.

## LUBRICATION OF FLEXIBLE SHAFT AND HOUSING

•The flexible shaft and housing must be lubricated before attaching them to the motor. The following procedure for lubrication is recommended:

1. In a location free of dirt and grit, lay the housing on a clean bench or table.
2. Take some Mobil XHP222 (No. 2 Lithium grease) or equivalent, in the palm of one hand and with the other hand guide flexible shaft through the hand containing lubricant into the flexible housing. This method will result in a thin uniform film covering the entire shaft. Over-lubrication will cause over-heating and possible damage to the shaft and housing. Lubricating a new shaft and housing requires a more generous portions of grease than when re-lubricating, because the shaft and housing absorb a certain amount of grease. After the first two hour of operation, the shaft should be inspected to determine whether it requires additional lubrication.
3. The flexible shaft should be re-lubricated after each 50 hours of use.

MOTOR BEARINGS ARE LUBRICATED AT THE FACTORY AND REQUIRE NO FURTHER ATTENTION.

## INSTALLING FLEXIBLE SHAFT AND HOUSING

•Pull the threaded end of the flexible shaft out of the housing about 12 inches. Screw the flexible housing onto the motor cover.

**CAUTION:** The housing should be tightened with a wrench and always kept tight on the motor cover to prevent wearing of the threads on both parts.

## OPERATION

•In using the flexible shaft, keep it as straight as possible. Sharp bends will cause excessive wear on the inside of the housing and shorten the useful life of both the shaft and housing.

## ORDERING PARTS

•When ordering parts, specify the model, part number, and name. If necessary, tag the old part and send with the order. Direct all inquires for motor parts or switch box to:

**Terrco® Inc.**

222 1st Avenue NW • Watertown, SD 57201  
Phone: (605) 882-3888 • Fax: (605) 882-0778  
Website: www.terrco.com • Email: info@terrco.com

## Terrco® Inc.

222 1st Avenue NW • Watertown, SD 57201

Phone: (605) 882-3888 • Fax: (605) 882-0778

Website: [www.terrco.com](http://www.terrco.com) • Email: [info@terrco.com](mailto:info@terrco.com)

# SAFETY INSTRUCTIONS

## READ INSTRUCTIONS PRIOR TO OPERATING THIS MACHINE

1. Have an electrician hook up power to machine.
2. Always operate machine with ground faults at the electrical source.
3. Always wear appropriate safety protection. Eye, hearing, and respiratory protection is advised.
4. Rotating grinding wheels can cause injury, keep hands and loose clothing clear.
5. Optional guards for wet or dry grinding.
6. Keep machine clean and serviced.